

■ TDZS-08-LED

■ LED Runway Touchdown Zone Light (8" 6mm)



Compliance with Standards

CAAC: AC-137-CA-2015-01
 CAAC: AC-137-CA-2015-03
 SAC: GB/T 7256
 ICAO: Annex 14, Volume I
 IEC: TS 61827
 FAA: AC 150/5345-46
 FAA: EB NO.67
 NATO: STANAG 3316

Application/Use

Runway touchdown zone light

Features

- LED is featured by long life, effective energy saving, maintenance-free, which brings enormous economic benefits
- Proprietary prism structural design and manufacturing process to ensure excellent optical performance
- Strict LED color management to ensure premium color consistency
- Consistent dimming curve with halogen lamp fixture, complying with FAA standards
- Proprietary driving circuit and thermal management solution, which greatly improves the reliability and service life of light fixture
- Power factor above 0.9, minimizing the power network interference
- Optional function of single lamp failure detection, which enables the light to be open as halogen lamp once LED fails
- Specially-designed structure, protruding only 6.35mm above finish grade
- Upper cover with flat out-light surface to prevent from water buildup and ensure high luminous efficiency
- Upper cover with equal-strength design and forging craft, which has premium mechanical, barrier capacity, and shock resistance ability
- Smooth upper cover without sharp edge to prevent aircraft tires from damaging
- Main body of lighting fixture is made of high thermal conductive aluminum alloy, which ensures good heat dissipation performance
- Main structure made of corrosion-resistant aluminum alloy with special anodizing treatment, all fasteners are made of stainless steel, suitable for harsh environment application
- High-precision parts machining to ensure all dimensional quality and precision
- IP68 Ingress protection-grade, that can withstand inner pressure of up to 138kpa or water pressure generated from aircrafts' impact on the optical window
- Interchangeable, modular-designed components, applicable for all series of 8-inch LED in-pavement runway lights(6 mm), which effectively cuts down the inventories.

Ordering Information

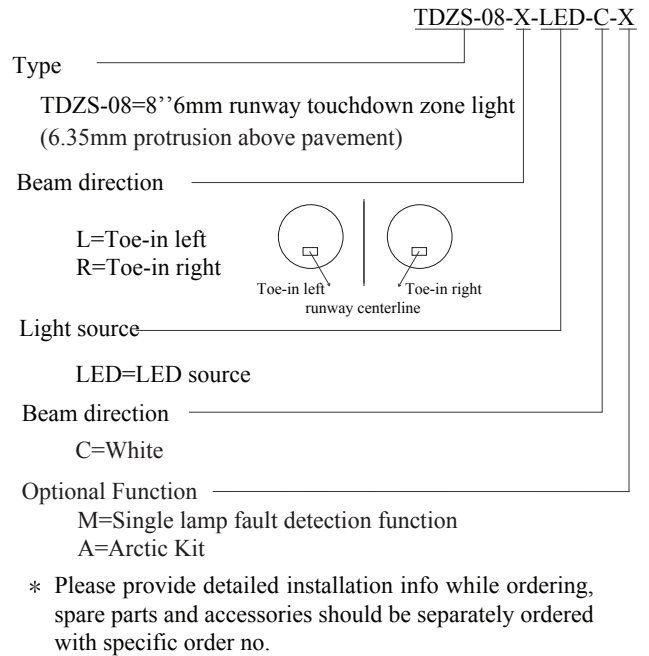

Installation

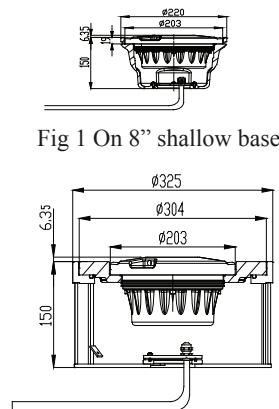

Fig 1 On 8" shallow base

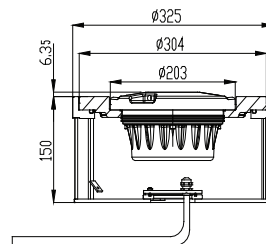

Fig 2. On 12" shallow base w/ 12"8" adapter ring

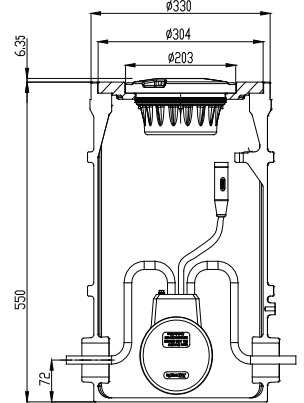
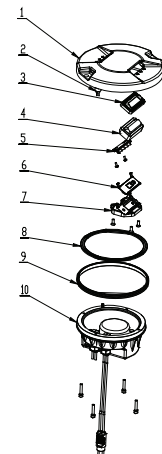

Fig 3. On 12" deep base w/ 12"8" adapter ring

* Please find detailed information in installation manual

Structure

1. upper cover
2. thermal switch
3. prism gasket sleeve
4. prism
5. LED lamp assy
6. prism gasket
7. prism pressing bracket
8. light body gasket
9. lighting fixture gasket
10. inner cover assy



■ TDZS-08-LED

■ LED Runway Touchdown Zone Light (8" 6mm)

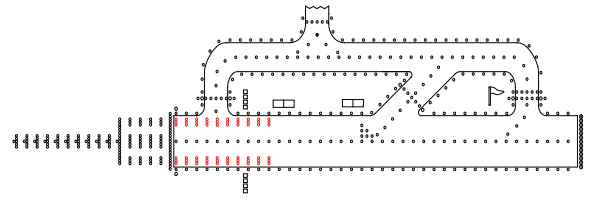

Specifications

Power: 20 VA

Power Factor: ≥ 0.9

Photometric Data

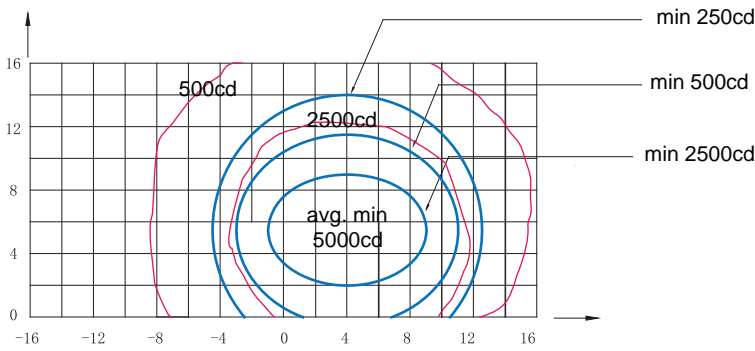

TDZS-08-LED (White), ICAO Figure A2-5, FAA L-850B

Application		Main Beam		Color	Required min avg. cd	Actual avg. cd
		H	V			
TDZS-08-LED	ICAO Figure A2-5/ FAA L-850B	$\pm 5^\circ$ (Toe-in 4°)	$2^\circ - 9^\circ$	White	5000	6683

Packing Data

1 lights w/o base

Unit net weight: 3.4 kg

1 light w/ 8" shallow base

Unit net weight: 6.4 kg

Packing size: 210×210×130mm³

Gross weight: 3.5 kg

Packing size: 240×240×180mm³

Gross weight: 6.5 kg

Spare Parts

Struc No	Part Name	Order No.	Description
3	prism gasket sleeve	43117	prism gasket sleeve (61×28)-H6
4	prism	31158	prism (61×28) -H6
5	LED lamp assy	932053 -TDZS-C	LED lamp assy-TDZS-C
6	prism gasket	43316	prism gasket(67×21)
7	prism pressing bracket	43241	prism pressing bracket(71×65)
8	light body gasket	41141	O-ring 137×2
9	light fixture gasket	41107	Seal belt(standard)

Accessories

No.	Order No.	Description
1	SB-08	8" shallow base
2	SB-12	12" shallow base
3	DB-12	12" deep base
4	AR-12/08	12"-8" adaptor ring
5	951101	8" lamp handle
6	ITF-045-066	45-watt isolation transformer
8	REC7	moulded type secondary cable receptacle style 7